

searle



MDG Air-Cooled Condensers 23 - 863kW



SPECIFICATION

General

The Searle MDG range of fully weather-proofed air cooled condensers consists of 104 models covering capacities from 23kW to 863kW (Eurovent Certified).

The range is modular in design with fans arranged in single rows from 1 to 5 and in double rows from 4 to 12.

The units can be operated in either a horizontal or vertical orientation. However, restrictions apply to their application in the vertical mode. (See INSTALLATION section in this literature).

The two-speed motors can be used either for night-time turn down or for control of head pressure. Night-time turn down can offer an acceptable day-time noise level with a considerably lower night-time sound emittance. Also substantial power savings can be achieved during periods of low ambient conditions.

The MDG range is suitable for most refrigeration and air conditioning applications. These condensers can also be configured as dry air liquid coolers - please refer to your supplier.

Casework

All casework including motor support brackets, air baffles and legs are manufactured from corrosion-resistant pre-galvanised steel.

Painted components feature hard wearing oven cured, UV-tolerant paint, applied in our electrostatic paint plant, which protects surfaces and cut edges.

Sturdy cross members fixed diagonally across each fan chamber support the motor and ensure the maximum rigidity of the structure. Each fan chamber is separated by internal baffle plates to prevent induced windmilling of off-cycle fans.

An optional coil cleaning port in the form of a hinged access panel can be provided in each fan section.

Optional leg extensions are available to enhance fresh air supply in difficult locations.

Coils

Standard coils are manufactured from Cu/Al Copper tube/Aluminium fin employing the latest extended inner surface technology. The tubes are mechanically expanded into fully-collared holes in the fin.

This ensures an effective and permanent bond between the expanded tube and the fin, maximising heat transfer characteristics.

Bushes are fitted between the tube and the tube plates to ensure that the coil is freely suspended.

Alternative fin materials are available to give added protection in saline or polluted atmospheres:-

Cu/Av Copper tube/Vinyl coated Aluminium fins

Cu/Cu Copper tubes/Copper fins

Cu/Et Copper tubes/Copper fins electroplated after assembly

Sub-cooling (Optional extra)

Sub-cooling is achieved by the use of an integrated sub-cooling section which utilises approximately 10% of the coil surface. This provides 7K of sub-cooling at the standard rating condition of 15K. Operating at a TD1 below 15K, the amount of sub-cooling is reduced.

The condenser heat of rejection capacity, inclusive of sub-cooling, will be reduced by 5%.

The system should be designed so that refrigerant passes from the condensing section into a liquid receiver or liquid trap to prevent gas entering the sub-cooling section.

Models above two fans long have intermediate connections (Outlet condensing, Inlet Sub-cooling) at the opposite end to the hot gas inlet.

Multi-sectioning

All models are suitable for multi-sectioning, permitting more than one refrigeration system to operate with a single condenser.

Fans

The standard fans are contoured propeller fans specifically designed by Searle to maximise the airside performance both in airflow and noise levels. The fans run in a deep bellmouth formed in the fanplate. The 4-bladed 910mm diameter fans have rear hubs and are complete with keyways and secured by grub screws. Different fans are used for each motor type and are therefore not interchangeable.

SPECIFICATION

Motors and Speed Control

Motors are foot-mounted onto rigid diagonal cross beams and individually wired to a common terminal box on the outside of the unit (refrigerant connection end). All motor enclosures are rated to a minimum IP55.

Standard motors are suitable for:
380 - 420/3/50 or 400 - 460/3/60 supplies.

Standard motors (6, 8, 12 and 16 pole) are Delta/Star connected, running at normal speed in Delta or low speed in Star. Units will be supplied Delta connected. Star connection can be achieved by changing connections in the standard terminal box at the end of the unit.

Two speed operation is achieved by remote switching of motors between Delta and Star connections. For this purpose, Searle offers a two-speed contactor box consisting of a mains isolator, motor circuit breakers and mechanically and electrically interlocked changeover contactors for each motor. For customer's own two-speed systems the use of an alternative terminal box is required - this should be specified at the time of ordering.

The two-speed control can be used in conjunction with the Searle range of microprocessor fan control systems which gives very close control of head pressure.

If a Searle control is not used, it is essential that the system selected has both mechanical and electrical interlocks to give maximum protection to the motors.

Head pressure and fluid temperature controls are available for the MDG. These range from a simple contactor box to a sophisticated microprocessor system, operating from either pressure or temperature sensors. Please refer to Searle's Controls brochure or contact your supplier for further assistance.

Additional Options

Motor internal protection (recommended with speed control)

Air Straighteners (not 6 pole) and extension legs for confined locations)

Operation against light external air resistances (delta speeds only)

Inverter speed control

Adiabatic cooling system

Anti-vibration mounts

Twin section control (via sequencial controller)

Individual motor isolators

Screened motor harness (for inverter control)

Rating conditions

The rating condition is based on the standard EN327 for condensers with a 15K temperature difference between ambient and condensing temperature and an electrical supply of 400V. Correction factors are supplied for alternative temperature differences.

Dew Point

The capacities shown in this document are rated at dew point. This is the pressure/temperature condition at which a refrigerant gas begins to condense on a surface. As some refrigerants now have significant glide (e.g. R407A/407C), the saturated gas and saturated liquid temperatures are not necessarily the same. Therefore it has become necessary to define the two conditions - saturated gas, now known as dew point and saturated liquid, now known as bubble point (the point at which liquid begins to boil).

It is important to ensure that all the components of a system are selected using the same rating method.

Noise levels

Sound power levels have been determined from tests carried out in free field conditions. Sound power (dBA) data has been verified and independently certified by Eurovent. Data for sound pressure levels has been derived from measurements taken during the independent testing. Published figures are for distances measured horizontally at fan deck height from the longest side of a horizontal unit, when mounted on a reflective plan. For approximate noise levels in the direction of air flows add 6dB(A).

Quality Assurance

Searle is a certified company to BS EN ISO 9001-2000 which is a Quality Management system, including Performance Testing, Manufacturing Systems and Inspection Procedures.

Certification

The range is certified under the Eurovent CERTIFY-ALL Air Cooled Condensers program, with performances rated in accordance with EN 327.



INSTALLATION AND LOCATION GUIDANCE

Consideration should be given to pipework associated with the installation which can be either an obstruction to air flow or a heat source to the air entering the coil. Other adjacent plant either requiring an air supply or dissipating air will affect the air flow onto the unit. The colour of the surface on which the units are mounted and/or surrounding areas can create high solar gains, increasing the entering air temperature considerably. A 5K temperature increase over and above ambient is not unusual. This obviously has a serious effect on the performance. Adjacent building styles, plant and prevailing winds can often cause air currents, which, in turn, can create downdraughts, consequently forcing the discharge air back down into the air intake stream, causing high air entering temperatures and subsequent loss of performance.

Vertical units must not be installed when either 16 pole (star/delta) or 12 pole (star) connected motors are employed. The reason for this restriction is that an adverse effect of the prevailing wind can overcome the power of the motor, making it impossible to start. When vertical units are to be installed, they should be orientated so that the air flow direction is similar to that of the summer prevailing wind. Also, the coil should be, as far as is practical, shaded from direct sunlight.

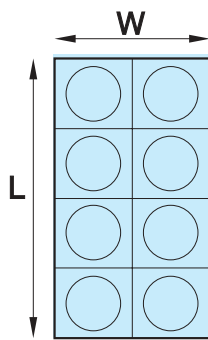

Fig 1
Single unit with no restriction within the unit's length has no limitations in use. For dimensions W and L refer to the dimensions tables.

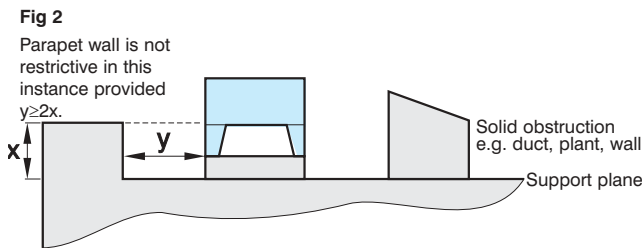

Fig 2
Parapet wall is not restrictive in this instance provided $y \geq 2x$.

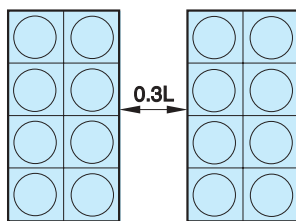

Fig 3
Multiple units with no restrictions within a distance equal to the unit's length have few limitations. However, the distance between units when more than 2 units in line are required is more critical. In this instance, it is worth considering increasing the leg height to give improved air circulation.

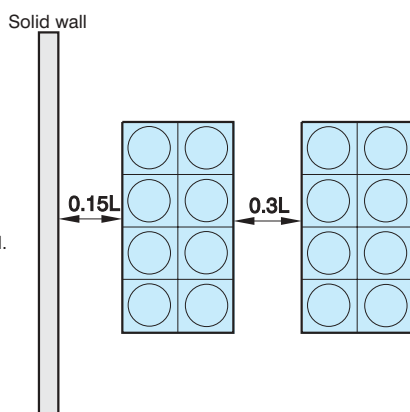

Fig 4
The dimension $0.15L$ is critical only if more than one unit is to be installed. If only one unit is installed, it can be located adjacent to the solid wall.

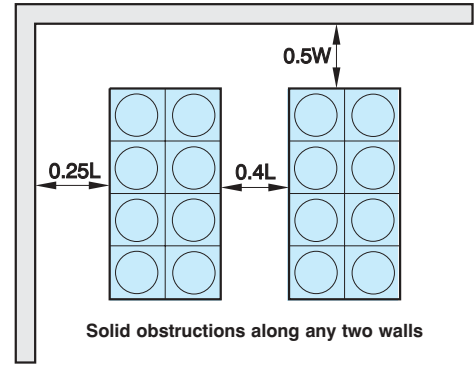

Fig 5
Please note pipework and other equipment sited adjacent to the units could well constitute an obstruction.

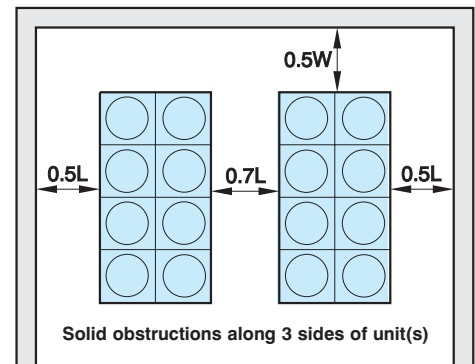

Fig 6
Where multiple units are located, the open side must give free air onto each unit. Raising units on extended legs or plinths will improve air circulation, and is recommended for 12 and 16-pole units.

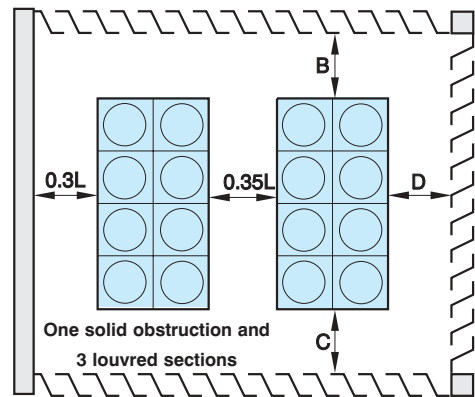

Fig 7
Free area of louvres should not be less than 70%.
 $B + C + D \geq L$
Fan discharge should be level with the top of the louvres.

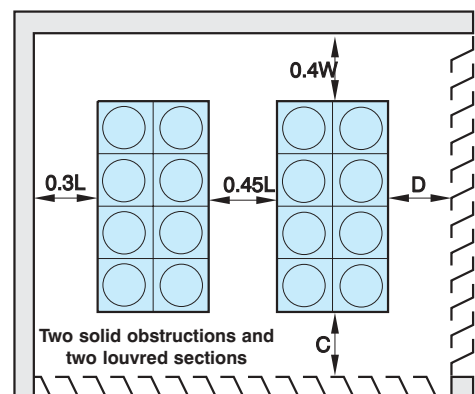

Fig 8
Total free area of the louvres should not be less than 70%.
 $D + C \geq 0.9L$
Fan discharge should be level with the top of the louvres.

HOW TO ORDER

MDG 255 -12 H AI 400/50 2S FCP DS P

TYPE

MODEL

MOTOR POLES (6, 8, 12 or 16)

ORIENTATION

H=Horizontal

V=Vertical

COIL MATERIAL

AI = Copper tubes/Aluminium fins

AV = Copper tubes/Vinyl coated Aluminium fins

Cu = Copper tubes/Copper fins

ET = Copper tubes/Copper fins

ELECTRICAL SUPPLY (V/Hz)

400/50

400/60

220/50

220/60

COIL CIRCUITING

2S = 2 Section

SC = Sub Cooling

CONTROLS

FCB Fan Contactor Box

FCT Intelligent Fan Control (Temperature Sensing)

FCP Intelligent Fan Control (Pressure Setting)

FS Fan Speed Control (3ph) (Triac or Inverter)

WIRING

D = Delta

S = Star

DS = Dual Speed

PACKING

SELECTION DATA

6 POLE

△ 930 rpm

| Model Modèle Modell | Capacity / Puissance / Leistung 15K DT1 * | | | | | Coil Details / Batterie / Kühlerblock | | | | | | | Motor / Moteur / Motor ** | | | | |
|---------------------------|---|-------------|-------|-------|--|---------------------------------------|--|---|-----------------------------|------------------------------|---|---|---|--|--|-----------------------------------|--|
| | R134a | R404A/R507A | R407A | R407C | Air Volume Débit d'air Luftstrom | Surface Area Surface Kühlfläche | Number of circuits Nombre de Anzahl der Kreisläufe | Fin Spacing Ecartement Ailettes Lamellenabstand | Inlet Entrée Eintritt | Outlet Sortie Austritt | Internal Volume Volume interne Rohrinhalt | R404A Charge R404A Charge R404A Füllung | Number of Nombre de Anzahl der Kreisläufe | Nominal Speed Vitesse Nominale Nenn Drehzahl | Power Input Puissance Absorbée Leistungsaufnahme | FLC Intensité Betriebsstrom | SC Intensité de démarrage Anlaufstrom |
| MDG | kW | kW | kW | kW | m³/s | m² | mm | Ø | Ø | dm³ | kg | | rpm /mm UpM | kW | A | A | |
| 10-6D | 46.9 | 50.4 | 41.8 | 43.8 | 6.25 | 64.6 | 6 | 2.12 | 2 1/8" | 1 3/8" | 16.4 | 5.3 | 1 | 930 | 2.45 | 5.4 | 25.0 |
| 20-6D | 59.0 | 63.4 | 52.6 | 55.2 | 5.90 | 96.9 | 9 | 2.12 | 2 1/8" | 1 3/8" | 22.9 | 7.5 | 1 | 930 | 2.45 | 5.4 | 25.0 |
| 30-6D | 66.9 | 71.9 | 59.7 | 62.6 | 5.45 | 129.3 | 12 | 2.12 | 2 1/8" | 1 3/8" | 29.3 | 9.5 | 1 | 930 | 2.45 | 5.4 | 25.0 |
| 40-6D | 93.8 | 100.8 | 83.6 | 87.6 | 12.50 | 129.3 | 12 | 2.12 | 2 1/8" | 1 3/8" | 28.1 | 9.1 | 2 | 930 | 2.45 | 5.4 | 25.0 |
| 50-6D | 118.0 | 126.8 | 105.2 | 110.4 | 11.80 | 193.9 | 18 | 2.12 | 2 1/8" | 1 3/8" | 40.4 | 13.1 | 2 | 930 | 2.45 | 5.4 | 25.0 |
| 60-6D | 133.8 | 143.8 | 119.4 | 125.2 | 10.90 | 258.5 | 24 | 2.12 | 2 1/8" | 1 3/8" | 52.7 | 17.1 | 2 | 930 | 2.45 | 5.4 | 25.0 |
| 80-6D | 177.0 | 190.2 | 157.8 | 165.6 | 17.70 | 290.8 | 27 | 2.12 | 2 5/8" | 1 5/8" | 59.7 | 19.4 | 3 | 930 | 2.45 | 5.4 | 25.0 |
| 90-6D | 200.7 | 215.7 | 179.1 | 187.8 | 16.35 | 387.8 | 35 | 2.12 | 2 5/8" | 1 5/8" | 77.9 | 25.3 | 3 | 930 | 2.45 | 5.4 | 25.0 |
| 110-6D | 236.0 | 253.6 | 210.4 | 220.8 | 23.60 | 387.8 | 27 | 2.12 | 2 5/8" | 1 5/8" | 77.3 | 25.1 | 4 | 930 | 2.45 | 5.4 | 25.0 |
| 115-6D | 236.0 | 253.6 | 210.4 | 220.8 | 23.60 | 387.8 | 36 | 2.12 | 2 x 2 1/8" | 2 x 1 3/8" | 80.9 | 26.3 | 2 x 2 | 930 | 2.45 | 5.4 | 25.0 |
| 120-6D | 267.6 | 287.6 | 238.8 | 250.4 | 21.80 | 517.0 | 35 | 2.12 | 3 1/8" | 2 1/8" | 104.0 | 33.8 | 4 | 930 | 2.45 | 5.4 | 25.0 |
| 125-6D | 267.6 | 287.6 | 238.8 | 250.4 | 21.80 | 517.0 | 48 | 2.12 | 2 x 2 1/8" | 2 x 1 3/8" | 110.0 | 35.6 | 2 x 2 | 930 | 2.45 | 5.4 | 25.0 |
| 140-6D | 295.0 | 317.0 | 263.0 | 275.2 | 29.50 | 484.7 | 54 | 2.12 | 3 1/8" | 2 1/8" | 97.5 | 31.6 | 5 | 930 | 2.45 | 5.4 | 25.0 |
| 150-6D | 334.5 | 359.5 | 298.5 | 313.0 | 27.25 | 646.3 | 35 | 2.12 | 3 1/8" | 2 1/8" | 127.0 | 41.3 | 5 | 930 | 2.45 | 5.4 | 25.0 |
| 175-6D | 354.0 | 380.4 | 315.6 | 331.2 | 35.40 | 581.6 | 54 | 2.12 | 2 x 2 5/8" | 2 x 1 5/8" | 120.0 | 38.8 | 2 x 3 | 930 | 2.45 | 5.4 | 25.0 |
| 185-6D | 401.4 | 431.4 | 358.2 | 375.6 | 32.70 | 775.5 | 70 | 2.12 | 2 x 2 5/8" | 2 x 1 5/8" | 156.0 | 50.5 | 2 x 3 | 930 | 2.45 | 5.4 | 25.0 |
| 205-6D | 472.0 | 507.2 | 420.8 | 441.6 | 47.20 | 775.5 | 54 | 2.12 | 2 x 2 5/8" | 2 x 1 5/8" | 155.0 | 50.1 | 2 x 4 | 930 | 2.45 | 5.4 | 25.0 |
| 215-6D | 535.2 | 575.2 | 477.6 | 500.8 | 43.60 | 1034.0 | 70 | 2.12 | 2 x 3 1/8" | 2 x 2 1/8" | 208.0 | 67.5 | 2 x 4 | 930 | 2.45 | 5.4 | 25.0 |
| 235-6D | 590.0 | 634.0 | 526.0 | 552.0 | 59.00 | 969.4 | 108 | 2.12 | 2 x 3 1/8" | 2 x 2 1/8" | 195.0 | 63.2 | 2 x 5 | 930 | 2.45 | 5.4 | 25.0 |
| 245-6D | 669.0 | 719.0 | 597.0 | 626.0 | 54.50 | 1292.5 | 70 | 2.12 | 2 x 3 1/8" | 2 x 2 1/8" | 255.0 | 82.6 | 2 x 5 | 930 | 2.45 | 5.4 | 25.0 |
| 265-6D | 708.0 | 760.8 | 631.2 | 662.4 | 70.80 | 1163.3 | 108 | 2.12 | 2 x 3 1/8" | 2 x 2 1/8" | 230.0 | 74.7 | 2 x 6 | 930 | 2.45 | 5.4 | 25.0 |
| 275-6D | 802.8 | 862.8 | 716.4 | 751.2 | 65.40 | 1551.0 | 144 | 2.12 | 2 x 3 1/8" | 2 x 2 1/8" | 301.0 | 98.0 | 2 x 6 | 930 | 2.45 | 5.4 | 25.0 |

△ 780 rpm

| Model Modèle Modell | Capacity / Puissance / Leistung 15K DT1 * | | | | | Coil Details / Batterie / Kühlerblock | | | | | | | Motor / Moteur / Motor ** | | | | |
|---------------------------|---|-------------|-------|-------|--|---------------------------------------|--|---|-----------------------------|------------------------------|---|---|---|--|--|-----------------------------------|--|
| | R134a | R404A/R507A | R407A | R407C | Air Volume Débit d'air Luftstrom | Surface Area Surface Kühlfläche | Number of circuits Nombre de Anzahl der Kreisläufe | Fin Spacing Ecartement Ailettes Lamellenabstand | Inlet Entrée Eintritt | Outlet Sortie Austritt | Internal Volume Volume interne Rohrinhalt | R404A Charge R404A Charge R404A Füllung | Number of Nombre de Anzahl der Kreisläufe | Nominal Speed Vitesse Nominale Nenn Drehzahl | Power Input Puissance Absorbée Leistungsaufnahme | FLC Intensité Betriebsstrom | SC Intensité de démarrage Anlaufstrom |
| MDG | kW | kW | kW | kW | m³/s | m² | mm | Ø | Ø | dm³ | kg | | rpm /mm UpM | kW | A | A | |
| 10-6S | 42.5 | 45.7 | 37.9 | 39.8 | 5.05 | 64.6 | 6 | 2.12 | 2 1/8" | 1 3/8" | 16.4 | 5.3 | 1 | 780 | 1.75 | 3.2 | 15.0 |
| 20-6S | 53.2 | 57.2 | 47.5 | 49.8 | 4.65 | 96.9 | 9 | 2.12 | 2 1/8" | 1 3/8" | 22.9 | 7.5 | 1 | 780 | 1.75 | 3.2 | 15.0 |
| 30-6S | 61.1 | 65.7 | 54.5 | 57.2 | 4.60 | 129.3 | 12 | 2.12 | 2 1/8" | 1 3/8" | 29.3 | 9.5 | 1 | 780 | 1.75 | 3.2 | 15.0 |
| 40-6S | 85.0 | 91.4 | 75.8 | 79.5 | 10.10 | 129.3 | 12 | 2.12 | 2 1/8" | 1 3/8" | 28.1 | 9.1 | 2 | 780 | 1.75 | 3.2 | 15.0 |
| 50-6S | 106.4 | 114.4 | 95.0 | 99.5 | 9.30 | 193.9 | 18 | 2.12 | 2 1/8" | 1 3/8" | 40.4 | 13.1 | 2 | 780 | 1.75 | 3.2 | 15.0 |
| 60-6S | 122.2 | 131.4 | 109.0 | 114.3 | 9.20 | 258.5 | 24 | 2.12 | 2 1/8" | 1 3/8" | 52.7 | 17.1 | 2 | 780 | 1.75 | 3.2 | 15.0 |
| 80-6S | 159.6 | 171.6 | 142.5 | 149.3 | 13.95 | 290.8 | 27 | 2.12 | 2 5/8" | 1 5/8" | 59.7 | 19.4 | 3 | 780 | 1.75 | 3.2 | 15.0 |
| 90-6S | 183.3 | 197.1 | 163.5 | 171.5 | 13.80 | 387.8 | 35 | 2.12 | 2 5/8" | 1 5/8" | 77.9 | 25.3 | 3 | 780 | 1.75 | 3.2 | 15.0 |
| 110-6S | 212.8 | 228.8 | 190.0 | 199.1 | 18.60 | 387.8 | 27 | 2.12 | 2 5/8" | 1 5/8" | 77.3 | 25.1 | 4 | 780 | 1.75 | 3.2 | 15.0 |
| 115-6S | 212.8 | 228.8 | 190.0 | 199.1 | 18.60 | 387.8 | 36 | 2.12 | 2 x 2 1/8" | 2 x 1 3/8" | 80.9 | 26.3 | 2 x 2 | 780 | 1.75 | 3.2 | 15.0 |
| 120-6S | 244.4 | 262.8 | 218.0 | 228.6 | 18.40 | 517.0 | 35 | 2.12 | 3 1/8" | 2 1/8" | 104.0 | 33.8 | 4 | 780 | 1.75 | 3.2 | 15.0 |
| 125-6S | 244.4 | 262.8 | 218.0 | 228.6 | 18.40 | 517.0 | 48 | 2.12 | 2 x 2 1/8" | 2 x 1 3/8" | 110.0 | 35.6 | 2 x 2 | 780 | 1.75 | 3.2 | 15.0 |
| 140-6S | 266.0 | 286.0 | 237.5 | 248.8 | 23.25 | 484.7 | 54 | 2.12 | 3 1/8" | 2 1/8" | 97.5 | 31.6 | 5 | 780 | 1.75 | 3.2 | 15.0 |
| 150-6S | 305.5 | 328.5 | 272.5 | 285.8 | 23.00 | 646.3 | 35 | 2.12 | 3 1/8" | 2 1/8" | 127.0 | 41.3 | 5 | 780 | 1.75 | 3.2 | 15.0 |
| 175-6S | 319.2 | 343.2 | 285.0 | 298.6 | 27.90 | 581.6 | 54 | 2.12 | 2 x 2 5/8" | 2 x 1 5/8" | 120.0 | 38.8 | 2 x 3 | 780 | 1.75 | 3.2 | 15.0 |
| 185-6S | 366.6 | 394.2 | 327.0 | 343.0 | 27.60 | 775.5 | 70 | 2.12 | 2 x 2 5/8" | 2 x 1 5/8" | 156.0 | 50.5 | 2 x 3 | 780 | 1.75 | 3.2 | 15.0 |
| 205-6S | 425.6 | 457.6 | 380.0 | 398.1 | 37.20 | 775.5 | 54 | 2.12 | 2 x 2 5/8" | 2 x 1 5/8" | 155.0 | 50.1 | 2 x 4 | 780 | 1.75 | 3.2 | 15.0 |
| 215-6S | 488.8 | 525.6 | 436.0 | 457.3 | 36.80 | 1034.0 | 70 | 2.12 | 2 x 3 1/8" | 2 x 2 1/8" | 208.0 | 67.5 | 2 x 4 | 780 | 1.75 | 3.2 | 15.0 |
| 235-6S | 532.0 | 572.0 | 475.0 | 497.6 | 46.50 | 969.4 | 108 | 2.12 | 2 x 3 1/8" | 2 x 2 1/8" | 195.0 | 63.2 | 2 x 5 | 780 | 1.75 | 3.2 | 15.0 |
| 245-6S | 611.0 | 657.0 | 545.0 | 571.6 | 46.00 | 1292.5 | 70 | 2.12 | 2 x 3 1/8" | 2 x 2 1/8" | 255.0 | 82.6 | 2 x 5 | 780 | 1.75 | 3.2 | 15.0 |
| 265-6S | 638.4 | 686.4 | 570.0 | 597.2 | 55.80 | 1163.3 | 108 | 2.12 | 2 x 3 1/8" | 2 x 2 1/8" | 230.0 | 74.7 | 2 x 6 | 780 | 1.75 | 3.2 | 15.0 |
| 275-6S | 733.2 | 788.4 | 654.0 | 685.9 | 55.20 | 1551.0 | 144 | 2.12 | 2 x 3 1/8" | 2 x 2 1/8" | 301.0 | 98.0 | 2 x 6 | 780 | 1.75 | 3.2 | 15.0 |

Correction Factors

(Multiply the above capacity by the following factors depending on the DT1 temperature difference)

| | DT1 | | | | | |
|--------------------|------|------|------|------|------|------|
| | 8K | 10K | 12K | 15K | 17K | 20K |
| R507, R134A, R404A | 0.53 | 0.67 | 0.80 | 1.00 | 1.13 | 1.33 |
| R4007A, R407C | 0.46 | 0.62 | 0.77 | 1.00 | 1.15 | 1.38 |

NOISE DATA

6 POLE

△ 930 rpm

| Model Modèle Modell | Sound Power Level Niveau de Puissance Sonore Schalleistungspegel | Sound Pressure Level (dB(A), NC & NR @ 10m) Niveau de Pression Sonore (dB(A), NC & NR @ 10m) Schalldruckpegel (dB(A), NC & NR @ 10m) | | | | | | | | | | | 5 m | | | 20 m | | | 40 m | | | 60 m | | | | |
|---------------------------|---|--|-------|----|-----|-----|-----|------|------|------|------|-------|-----|----|-------|------|----|-------|------|----|-------|------|----|-------|----|----|
| | | Octave Band Frequency (Hz) Bande de Fréquence (Hz) Oktavband Frequenz (Hz) | | | | | | | | 10 m | | | | | | | | | | | | | | | | |
| | | MDG | dB(A) | 63 | 125 | 250 | 500 | 1000 | 2000 | 4000 | 8000 | dB(A) | NC | NR | dB(A) | NC | NR | dB(A) | NC | NR | dB(A) | NC | NR | dB(A) | NC | NR |
| 10-6D | | | | | | | | | | | | | | | | | | | | | | | | | | |
| 20-6D | 88 | | 51 | 56 | 53 | 49 | 48 | 44 | 39 | 38 | 53 | 48 | 49 | 58 | 54 | 55 | 47 | 42 | 43 | 41 | 37 | 38 | 38 | 33 | 34 | |
| 30-6D | | | | | | | | | | | | | | | | | | | | | | | | | | |
| 40-6D | | | | | | | | | | | | | | | | | | | | | | | | | | |
| 50-6D | 91 | | 54 | 59 | 56 | 52 | 51 | 47 | 42 | 41 | 56 | 51 | 52 | 61 | 57 | 58 | 50 | 45 | 46 | 44 | 40 | 41 | 41 | 36 | 37 | |
| 60-6D | | | | | | | | | | | | | | | | | | | | | | | | | | |
| 80-6D | 93 | 93 | 55 | 61 | 58 | 54 | 53 | 49 | 43 | 43 | 58 | 53 | 54 | 63 | 58 | 59 | 52 | 47 | 48 | 46 | 41 | 42 | 42 | 38 | 39 | |
| 90-6D | | | | | | | | | | | | | | | | | | | | | | | | | | |
| 110-6D | 94 | | 56 | 62 | 59 | 55 | 54 | 50 | 44 | 44 | 59 | 54 | 55 | 64 | 60 | 61 | 53 | 48 | 49 | 47 | 43 | 44 | 44 | 39 | 40 | |
| 120-6D | | | | | | | | | | | | | | | | | | | | | | | | | | |
| 115-6D | 94 | | 56 | 62 | 59 | 55 | 54 | 50 | 44 | 44 | 59 | 54 | 55 | 64 | 60 | 61 | 53 | 48 | 49 | 47 | 43 | 44 | 44 | 39 | 40 | |
| 125-6D | | | | | | | | | | | | | | | | | | | | | | | | | | |
| 140-6D | 95 | | 57 | 63 | 60 | 56 | 55 | 51 | 45 | 45 | 60 | 55 | 56 | 65 | 60 | 61 | 54 | 49 | 50 | 48 | 44 | 45 | 45 | 40 | 41 | |
| 150-6D | | | | | | | | | | | | | | | | | | | | | | | | | | |
| 175-6D | 95 | | 58 | 64 | 60 | 57 | 56 | 51 | 46 | 46 | 60 | 56 | 57 | 65 | 61 | 62 | 55 | 50 | 51 | 49 | 44 | 45 | 45 | 41 | 42 | |
| 185-6D | | | | | | | | | | | | | | | | | | | | | | | | | | |
| 205-6D | 96 | | 59 | 65 | 61 | 58 | 57 | 52 | 47 | 47 | 61 | 57 | 58 | 66 | 62 | 63 | 56 | 51 | 52 | 50 | 45 | 46 | 47 | 42 | 43 | |
| 215-6D | | | | | | | | | | | | | | | | | | | | | | | | | | |
| 235-6D | 97 | | 60 | 66 | 62 | 59 | 58 | 53 | 48 | 48 | 62 | 58 | 59 | 67 | 63 | 64 | 57 | 52 | 53 | 51 | 46 | 47 | 48 | 43 | 44 | |
| 245-6D | | | | | | | | | | | | | | | | | | | | | | | | | | |
| 265-6D | 98 | | 61 | 66 | 63 | 60 | 59 | 54 | 49 | 49 | 63 | 58 | 59 | 68 | 63 | 64 | 58 | 53 | 54 | 52 | 47 | 48 | 48 | 44 | 45 | |
| 275-6D | | | | | | | | | | | | | | | | | | | | | | | | | | |

6 POLE Δ/Δ
48-63 dB(A) 10m

∩ 780 rpm

| Model Modèle Modell | Sound Power Level Niveau de Puissance Sonore Schalleistungspegel | Sound Pressure Level (dB(A), NC & NR @ 10m) Niveau de Pression Sonore (dB(A), NC & NR @ 10m) Schalldruckpegel (dB(A), NC & NR @ 10m) | | | | | | | | | | | 5 m | | | 20 m | | | 40 m | | | 60 m | | | |
|---------------------------|---|--|-------|----|-----|-----|-----|------|------|------|------|-------|-----|----|-------|------|----|-------|------|----|-------|------|----|-------|----|
| | | Octave Band Frequency (Hz) Bande de Fréquence (Hz) Oktavband Frequenz (Hz) | | | | | | | | 10 m | | | | | | | | | | | | | | | |
| | | MDG | dB(A) | 63 | 125 | 250 | 500 | 1000 | 2000 | 4000 | 8000 | dB(A) | NC | NR | dB(A) | NC | NR | dB(A) | NC | NR | dB(A) | NC | NR | dB(A) | NC |
| 10-6S | | | | | | | | | | | | | | | | | | | | | | | | | |
| 20-6S | 83 | | 45 | 51 | 49 | 44 | 43 | 38 | 34 | 33 | 48 | 43 | 44 | 53 | 49 | 50 | 42 | 37 | 38 | 36 | 31 | 32 | 32 | 27 | 29 |
| 30-6S | | | | | | | | | | | | | | | | | | | | | | | | | |
| 40-6S | | | | | | | | | | | | | | | | | | | | | | | | | |
| 50-6S | 86 | | 48 | 54 | 52 | 47 | 46 | 41 | 37 | 36 | 51 | 46 | 47 | 56 | 52 | 53 | 45 | 40 | 41 | 39 | 34 | 35 | 35 | 31 | 32 |
| 60-6S | | | | | | | | | | | | | | | | | | | | | | | | | |
| 80-6S | 88 | | 50 | 56 | 54 | 49 | 48 | 43 | 38 | 38 | 53 | 48 | 49 | 58 | 53 | 54 | 47 | 42 | 43 | 41 | 36 | 37 | 37 | 33 | 34 |
| 90-6S | | | | | | | | | | | | | | | | | | | | | | | | | |
| 110-6S | 89 | | 51 | 57 | 55 | 50 | 49 | 44 | 40 | 39 | 54 | 49 | 50 | 59 | 54 | 55 | 48 | 43 | 44 | 42 | 37 | 38 | 38 | 34 | 35 |
| 120-6S | | | | | | | | | | | | | | | | | | | | | | | | | |
| 115-6S | 89 | | 51 | 57 | 55 | 50 | 49 | 44 | 40 | 39 | 54 | 49 | 50 | 58 | 54 | 55 | 48 | 43 | 44 | 42 | 37 | 38 | 38 | 34 | 35 |
| 125-6S | | | | | | | | | | | | | | | | | | | | | | | | | |
| 140-6S | 90 | | 52 | 58 | 56 | 51 | 50 | 45 | 41 | 40 | 55 | 50 | 51 | 60 | 55 | 56 | 49 | 44 | 45 | 43 | 38 | 39 | 39 | 35 | 36 |
| 150-6S | | | | | | | | | | | | | | | | | | | | | | | | | |
| 175-6S | 90 | | 53 | 59 | 56 | 51 | 51 | 46 | 41 | 40 | 55 | 50 | 51 | 60 | 56 | 57 | 49 | 45 | 46 | 44 | 39 | 40 | 40 | 36 | 37 |
| 185-6S | | | | | | | | | | | | | | | | | | | | | | | | | |
| 205-6S | 91 | | 54 | 60 | 57 | 52 | 52 | 47 | 42 | 41 | 56 | 52 | 53 | 61 | 57 | 58 | 51 | 46 | 47 | 45 | 40 | 41 | 41 | 37 | 38 |
| 215-6S | | | | | | | | | | | | | | | | | | | | | | | | | |
| 235-6S | 92 | | 55 | 61 | 58 | 53 | 53 | 48 | 43 | 42 | 57 | 53 | 54 | 62 | 58 | 59 | 52 | 47 | 48 | 46 | 41 | 42 | 42 | 38 | 39 |
| 245-6S | | | | | | | | | | | | | | | | | | | | | | | | | |
| 265-6S | 93 | | 56 | 62 | 59 | 54 | 53 | 48 | 44 | 43 | 58 | 53 | 54 | 63 | 58 | 59 | 52 | 48 | 49 | 47 | 42 | 43 | 43 | 39 | 40 |
| 275-6S | | | | | | | | | | | | | | | | | | | | | | | | | |

Notes * Dew Point
** Motors

The capacities shown in this document are rated at dew point.
Figures in the tables are for 400V/3Ph/50Hz operation and are per motor

DIMENSIONS

MDG Layout

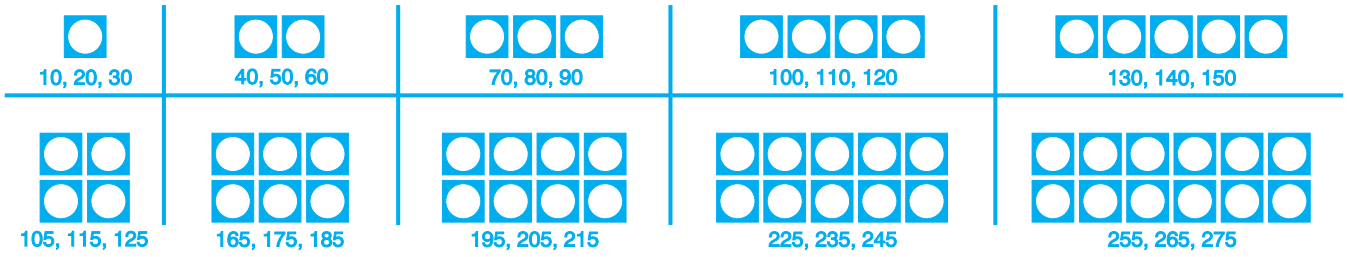

Horizontal Units

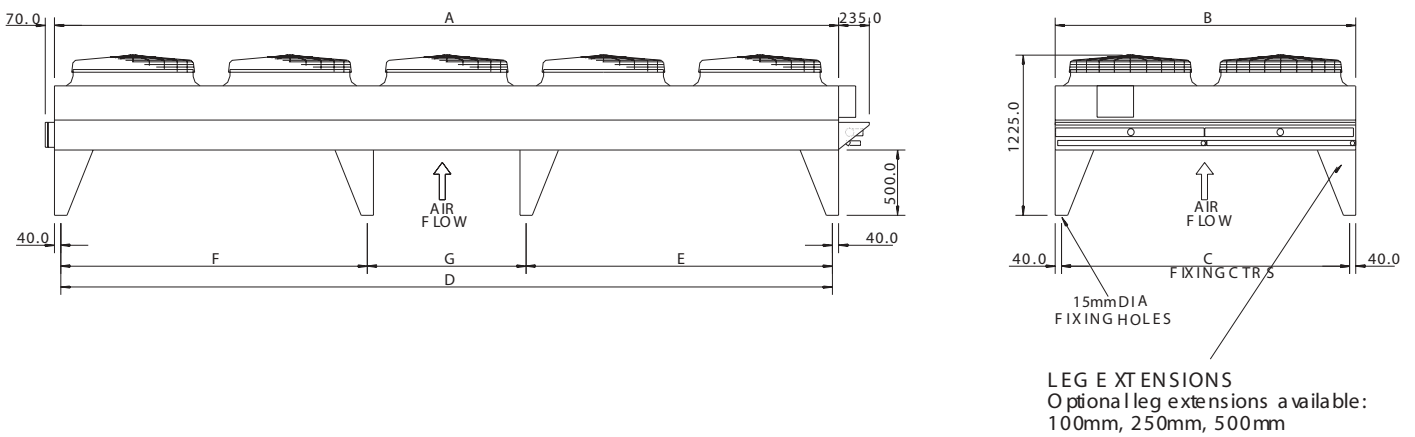

Vertical Units

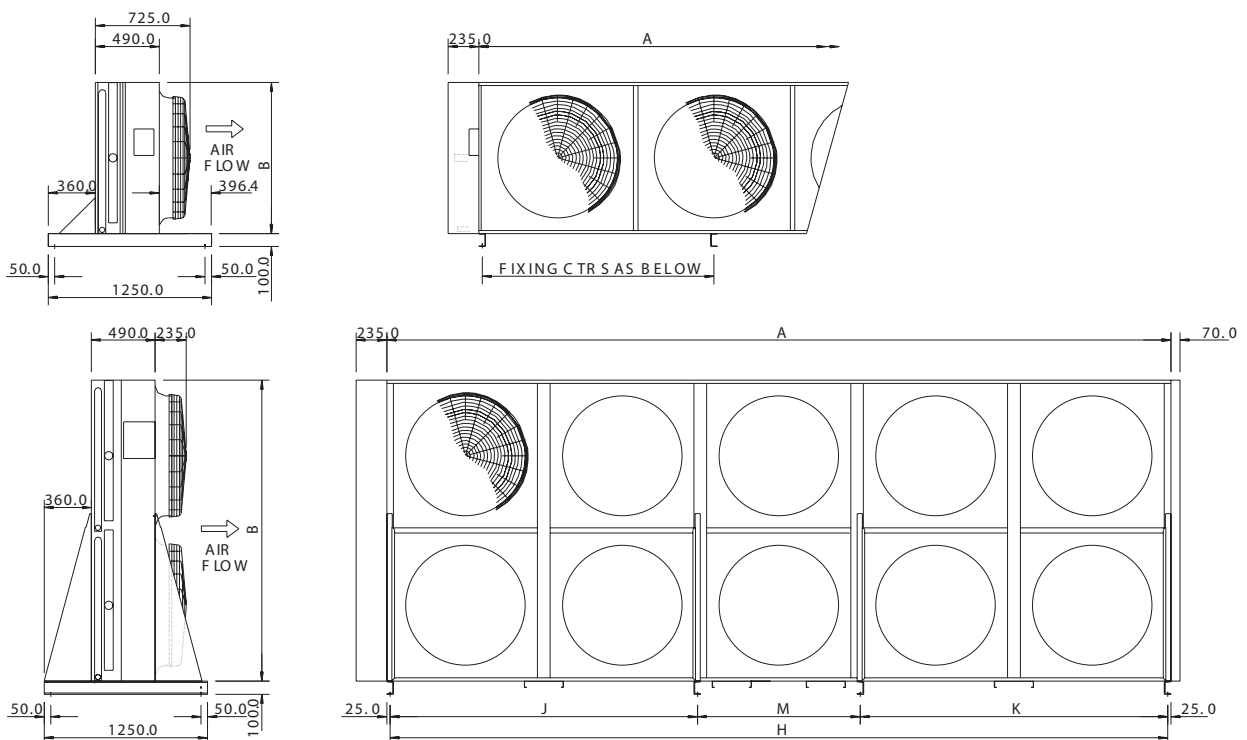

DIMENSIONS

| MDG | All dimensions in mm | | | | | | | | | | |
|-----|----------------------|------|------|------|------|------|------|------|--------|------|------|
| | A | B | C | D | E | F | G | H | J | K | M |
| 10 | 1203 | 1158 | 1078 | 1123 | - | - | - | 1153 | - | - | - |
| 20 | 1203 | 1158 | 1078 | 1123 | - | - | - | 1153 | - | - | - |
| 30 | 1203 | 1158 | 1078 | 1123 | - | - | - | 1153 | - | - | - |
| 40 | 2403 | 1158 | 1078 | 2323 | - | - | - | 2353 | - | - | - |
| 50 | 2403 | 1158 | 1078 | 2323 | - | - | - | 2353 | - | - | - |
| 60 | 2403 | 1158 | 1078 | 2323 | - | - | - | 2353 | - | - | - |
| 70 | 3603 | 1158 | 1078 | 3523 | - | - | - | 3553 | - | - | - |
| 80 | 3603 | 1158 | 1078 | 3523 | - | - | - | 3553 | - | - | - |
| 90 | 3603 | 1158 | 1078 | 3523 | - | - | - | 3553 | - | - | - |
| 100 | 4803 | 1158 | 1078 | 4723 | 2361 | 2361 | - | 4753 | 2353 | 2400 | - |
| 105 | 2403 | 2301 | 2221 | 2323 | - | - | - | 2353 | - | - | - |
| 110 | 4803 | 1158 | 1078 | 4723 | 2361 | 2361 | - | 4753 | 2353 | 2400 | - |
| 115 | 2403 | 2301 | 2221 | 2323 | - | - | - | 2353 | - | - | - |
| 120 | 4803 | 1158 | 1078 | 4723 | 2361 | 2361 | - | 4753 | 2353 | 2400 | - |
| 125 | 2403 | 2301 | 2221 | 2323 | - | - | - | 2353 | - | - | - |
| 130 | 6003 | 1158 | 1078 | 5923 | 2361 | 2361 | 1200 | 5953 | 2353 | 2353 | 1247 |
| 140 | 6003 | 1158 | 1078 | 5923 | 2361 | 2361 | 1200 | 5953 | 2353 | 2353 | 1247 |
| 150 | 6003 | 1158 | 1078 | 5923 | 2361 | 2361 | 1200 | 5953 | 2353 | 2353 | 1247 |
| 165 | 3603 | 2301 | 2221 | 3523 | - | - | - | 3553 | 1751.5 | - | - |
| 175 | 3603 | 2301 | 2221 | 3523 | - | - | - | 3553 | 1751.5 | - | - |
| 185 | 3603 | 2301 | 2221 | 3523 | - | - | - | 3553 | 1751.5 | - | - |
| 195 | 4803 | 2301 | 2221 | 4723 | 2361 | 2361 | - | 4753 | 2353 | 2400 | - |
| 205 | 4803 | 2301 | 2221 | 4723 | 2361 | 2361 | - | 4753 | 2353 | 2400 | - |
| 215 | 4803 | 2301 | 2221 | 4723 | 2361 | 2361 | - | 4753 | 2353 | 2400 | - |
| 225 | 6003 | 2301 | 2221 | 5923 | 2361 | 2361 | 1200 | 5953 | 2353 | 2353 | 1247 |
| 235 | 6003 | 2301 | 2221 | 5923 | 2361 | 2361 | 1200 | 5953 | 2353 | 2353 | 1247 |
| 245 | 6003 | 2301 | 2221 | 5923 | 2361 | 2361 | 1200 | 5953 | 2353 | 2353 | 1247 |
| 255 | 7203 | 2301 | 2221 | 7123 | 2361 | 2361 | 2400 | 7153 | 2353 | 2353 | 2447 |
| 265 | 7203 | 2301 | 2221 | 7123 | 2361 | 2361 | 2400 | 7153 | 2353 | 2353 | 2447 |
| 275 | 7203 | 2301 | 2221 | 7123 | 2361 | 2361 | 2400 | 7153 | 2353 | 2353 | 2447 |

WEIGHTS

| MDG | Approximate Weight Al (kg) | | Approximate Weight Cu (kg) | |
|-----|----------------------------|----------------|----------------------------|----------------|
| | 6 and 8 pole | 12 and 16 pole | 6 and 8 pole | 12 and 16 pole |
| 10 | 184 | 178 | 223 | 217 |
| 20 | 201 | 191 | 260 | 240 |
| 30 | 217 | 205 | 295 | 271 |
| 40 | 304 | 302 | 393 | 381 |
| 50 | 345 | 327 | 462 | 424 |
| 60 | 374 | 353 | 530 | 483 |
| 70 | - | 426 | - | 544 |
| 80 | 490 | 461 | 666 | 607 |
| 90 | 535 | 501 | 770 | 697 |
| 100 | - | 573 | - | 730 |
| 105 | - | 534 | - | 690 |
| 110 | 656 | 620 | 891 | 815 |
| 115 | 619 | 581 | 854 | 776 |
| 120 | 718 | 674 | 1031 | 935 |
| 125 | 677 | 635 | 990 | 896 |
| 130 | - | 717 | - | 913 |
| 140 | 821 | 772 | 1115 | 1017 |
| 150 | 895 | 842 | 1287 | 1168 |
| 165 | - | 767 | - | 1002 |
| 175 | 892 | 792 | 1244 | 1085 |
| 185 | 982 | 915 | 1451 | 1306 |
| 195 | - | 1019 | - | 1332 |
| 205 | 1182 | 1108 | 1652 | 1499 |
| 215 | 1306 | 1217 | 1932 | 1739 |
| 225 | - | 1357 | - | 1863 |
| 235 | 1601 | 1475 | 2303 | 2079 |
| 245 | 1760 | 1625 | 2657 | 2392 |
| 255 | - | 1496 | - | 2110 |
| 265 | 1754 | 1632 | 2602 | 2365 |
| 275 | 1928 | 1801 | 2991 | 2727 |



searle

*Searle Manufacturing Company
Newgate Lane Fareham
Hampshire PO14 1AR UK*

*Telephone +44 (0)1329 823344
Facsimile +44 (0)1329 821242
Email sales@searle.co.uk
Website www.searle.co.uk*

We reserve the right to change in whole or part, the specification detailed in this brochure without prior notice and, when necessary to achieve continuous production, to use alternative competitive designs of sub contract components made by various manufacturers.

Bulletin No. MDG SEP03/01 Part No. 273-102-033